

smp

SECURITY

Concept 2



MAKERS OFF FINE CASH SAFES

A safe for the future...

Today's modern safe draws on the latest in design and materials, developing high performance lightweight cash and jewellery safes to new exacting standards established by British and European Standard Institutes known as BS EN 14450: 2005. Domestic and small business safes had not been governed by European Standards until 2005 and S.M.P. Security have been working hard to produce an affordable cash and jewellery safe to match and exceed these standards.

S.M.P. Security tested this latest range of Concept safes at the British Research Establishment, and furthermore as an added feature of a Fire Test to BS 476 Part: 20, which will protect documents in a fire for up to thirty minutes. Available in 7 very usable sizes to suit all types of storage needs.

The new Concept 2 is the future for cash and jewellery safes for ALL RISKS up to £4000 overnight or up to £40,000 jewellery risk. The Cash Risk is a minimum risk but any jewellery risk should be confirmed by your Insurer.



Concept 2



Design

Concept 2 is designed to Security Level 2 to protect cash and valuables from unauthorised removal in either commercial or domestic situations.

The outer and inner Bodies are formed from a high grade steel giving an overall thickness of 50mm. Strategic points are protected by Anti Drill Inserts.

The Outer Door Plate is 6mm thick steel with an additional 2mm thick formed steel Lock Chamber.

Vital Locking areas are protected by a hardened drill resisting insert which gives an overall metal thickness over the Lock of 14mm.

The Door is secured by 3 way moving Boltwork.

Risk Cover

The Overnight Cash Risk for Security Level 2 is: £4000

or

Jewellery risk: £40,000 - (Please contact your Insurance company for confirmation)

Fire protection

An intumescent fire seal is set around the safe Body aperture to give thermal protection between the Door and Body.

Fire insulation is also included in the Lock Chamber.

Body void is packed with a Fire / Heat resistant material.

The Concept 2 has been independently Fire Tested to BS476 Part: 20 1987 for document protection and was subjected to temperatures of 850° C.

Locking

Concept 2 is locked by a Class 1 Lock which is protected by a dead re-locking device.

Anchoring

Anchoring of the unit is provided for by two Base Fix and / or a Central Back Fix position.

Internal Fittings

All safes are supplied with an adjustable shelf. Lockable full width Drawers are also available.

Deposit Facilities – (Available as an Optional Extra – On Request Only)

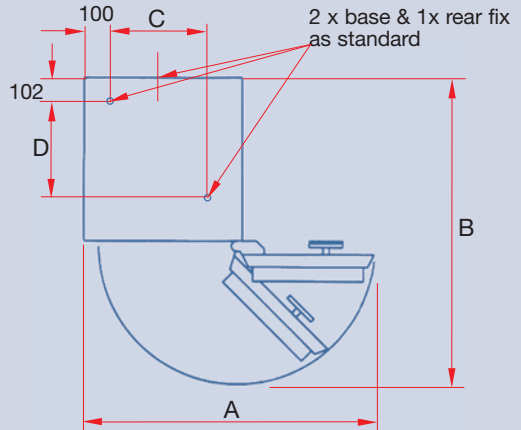

Size	A	B	C	D
1	631 (24.8)	671 (26.4)	182 (7.2)	156 (6.1)
2	727 (28.6)	719 (28.3)	230 (9.1)	156 (6.1)
3	845 (28.6)	878 (34.6)	289 (11.4)	256 (10)
4	845 (28.6)	878 (34.6)	289 (11.4)	256 (10)
5	845 (28.6)	878 (34.6)	289 (11.4)	256 (10)
6	1083 (42.6)	1197 (47.1)	408 (16.1)	456 (18)
7	1083 (42.6)	1197 (47.1)	408 (16.1)	456 (18)

Size	External			Internal			Wt Kgs	Vol. Litres
	H	W	D	H	W	D		
1	436 (17.2)	382 (15)	382 (15)	334 (13.2)	282 (11.1)	250 (9.8)	34	23
2	536 (21.1)	430 (16.9)	382 (15)	434 (17.1)	330 (13)	250 (9.8)	43	35
3	491 (19.3)	489 (19.3)	482 (19)	389 (15.3)	389 (15.3)	350 (13.8)	50	53
4	666 (26.2)	489 (19.3)	482 (19)	564 (22.2)	389 (15.3)	350 (13.8)	63	77
5	816 (32.1)	489 (19.3)	482 (19)	714 (28.1)	389 (15.3)	350 (13.8)	75	97
6	1010 (39.8)	608 (24)	682 (26.8)	908 (35.8)	508 (20)	550 (21.7)	125	253
7	1372 (54)	608 (24)	682 (26.8)	1270 (50)	508 (20)	550 (21.7)	162	354

All dimensions in mm - Dimensions in brackets are inches

- Conforms to BS EN 14450: 2005 requirements
- Fire Test : BS476 Part 20
- Seven sizes available
- Different locking options available
- Suggested overnight cash risk - £4,000
- Suggested jewellery risk - £40,000
- Insurance approved



In house testing is continually carried out on new materials

Case history



One of our safes was recently removed from a Poundstretcher store after an intense fire. The SMP safe, which is tested to BS476 Part 20 fire resistance, was technically opened by one of our engineers who found the cash held in it unmarked and acceptable for banking. This proves that SMP safes not only protect cash and valuables against theft but also fire damage.

Our customer at Poundstretcher said he was "over the moon"

S.M.P. Security is a leading manufacturer and supplier of Security equipment in the U.K.

With over 30 years experience, we produce safes to hold valuables worth up to £1 million. The current product range consists of safes which meet or exceed current European Standards.

If you are thinking security, S.M.P. will have a safe to meet your demands.

In the interest of improved design, SMP reserve the right to alter any specification without prior notice. Reference Trades Description Act 1968, all measurements must be considered to be approximate.



post

SMP Security Ltd.
Halesfield 24, Telford,
Shropshire TF7 4NZ



telephone
01952 585673



Facsimile
01952 582816



website/email
www.smpsecurity.co.uk
sales@smpsecurity.co.uk